

RACKING & WARE HOUSE

STORAGE GUIDE



WE ARE COMMITTED TO CUSTOMER SATISFACTION



AN ISO 9001:2008 COMPANY



ABOUT US

At Darshan Industries, we are the industry's key players and the leading manufacturers of storage systems. We manufacture and supply a huge range of multi storage systems using innovative technologies keeping a focus on significant market trends and requirements.

Our multi range of storage systems are suitable for a wide variety of users and industries. Besides storage systems, we are leading heavy duty manufacturers and strive to provide highly user friendly storage solutions for manufacturers and diverse industries.

All our products and services integrate quality and affordability at its best. As the renowned suppliers of storage systems, it is our objective to deliver quality products and services as per customer requirements and to their best satisfaction.



QUALITY POLICY

it is our objective to Deliver Quality Products and service. as per customer requirements and to their best satisfaction it is also our objective to build the organization of repute to meet this our efforts shall be:



VISION

The vision inspired DARSHAN INDUSTRIES group ensures strict adherence to quality standard at each and every stage of operation. the group has translated its commitment to quality into clear objectives where strategies and plans are shared by the entire organization.



SPIDER

MULTI RANGE OF STORAGE

- AHMEDABAD -

INDEX

HEAVY DUTY STORAGE P-04

TWO-TIER RACKING P-05

PALLET RACKING P-06

DRIVIN RACK P-08

ROLL RACK P-09

MEZZANINE FLOOR P-10

MOULD RACK P-12

MOTORIZED MOBILE PALLET RACKING P-14

SHEET STORAGE RACK P-16

LOCKERS P-17

MOBILE RACKING P-18

TOOLS TROLLEY P-20

HEAVY DUTY STORAGE



FEATURES

- Available in wide range of sizes and duties
- Easily configured to meet your load volume, weight and handling requirements
- Adjustable beam levels for varying pallet heights
- Aisles designed for counter balance or reach truck operations.

BENEFITS

- Offers easy accessibility to pallets easily manages nonuniform loads easily installed whilst its versatility makes it a cost effective solution.
- Does not require specialist truck training

USERS

- Industrie
- Educational Institutes
- Automotive Components
- Pharma Industries
- Supermarkets
- Warehousing
- Logistic companies
- Others



FEATURES

- A strong stable new floor to hold additional storage
- Can be designed to offer the greatest clear space on the ground for additional activities/storage

BENEFITS

- Enables you to maximise the usable height within your warehouse
- Reduces Cost of Construction by allowing efficient use of space
- No extra costs for heat, lights, or air conditioning
- Can be easily enlarged, modified, or moved
- Two tier wide space racks
- Gives additional space without adding ratable value to your property

USERS

- Industries
- Pharma Industries
- Warehousing
- Logistic Companies
- Others

TWO-TIER RACKING



PALLET RACKING

FEATURES

- Durable
- Precision Engineered
- Smooth Edges
- Efficient storage capacity
- Direct access to every pallet.
- Pallet can be removed Without Moving or Displacing Others
- Makes stock control easy, since each pallet has its own location
- Can be adapted to any size or weight of pallet

BENEFITS

- Automatic Stock rotation
- Offers high levels of storage density

USERS

- Industries
- Pharma Industries
- Warehousing
- Logistic Companies

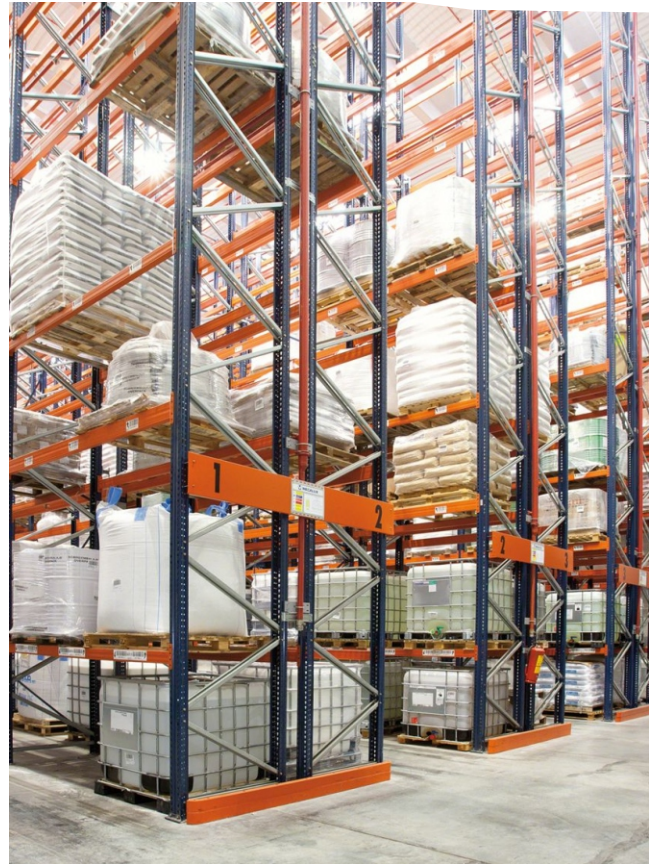

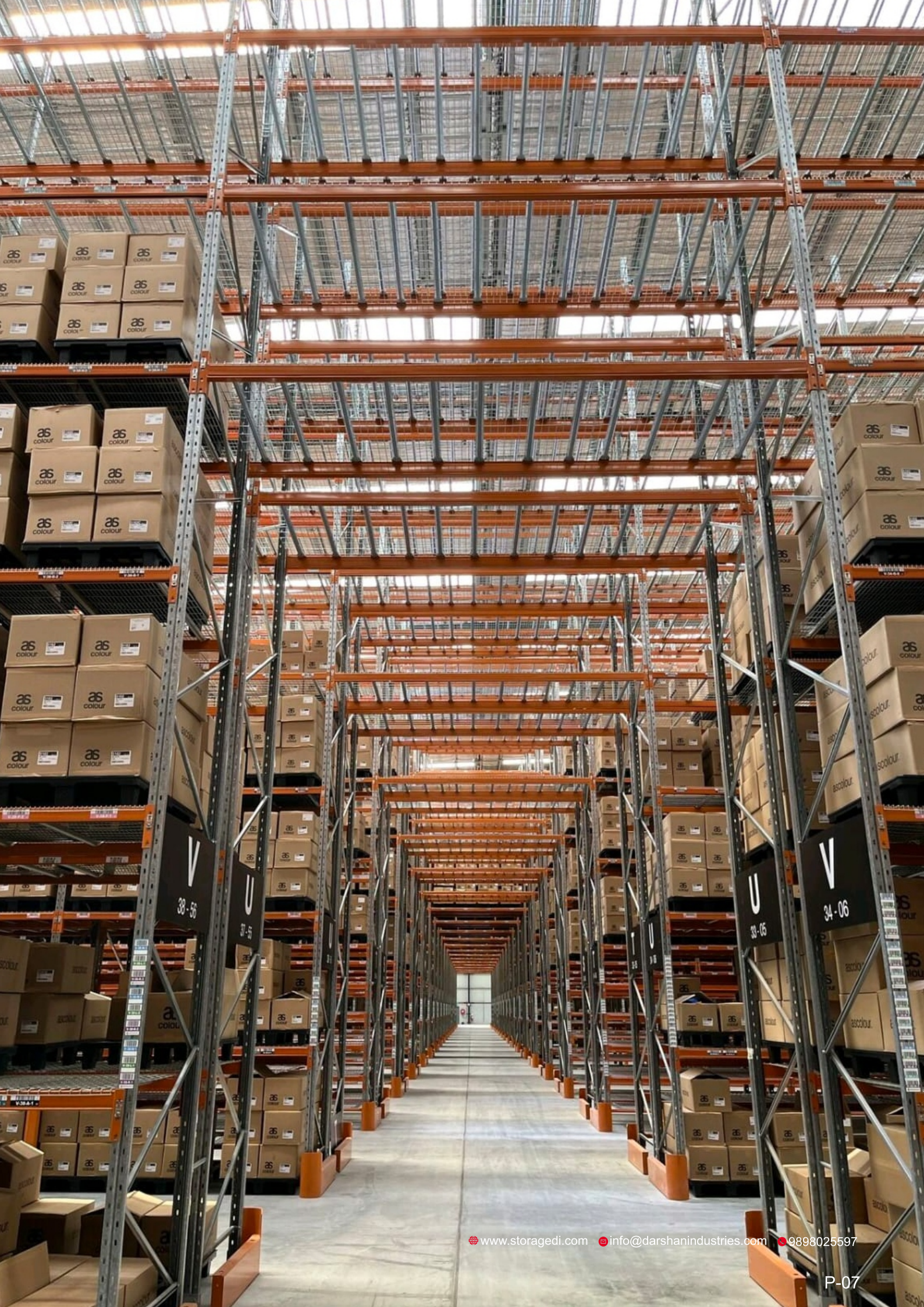

V
33-55

U
33-15

V
34-06

DRIVIN RACK

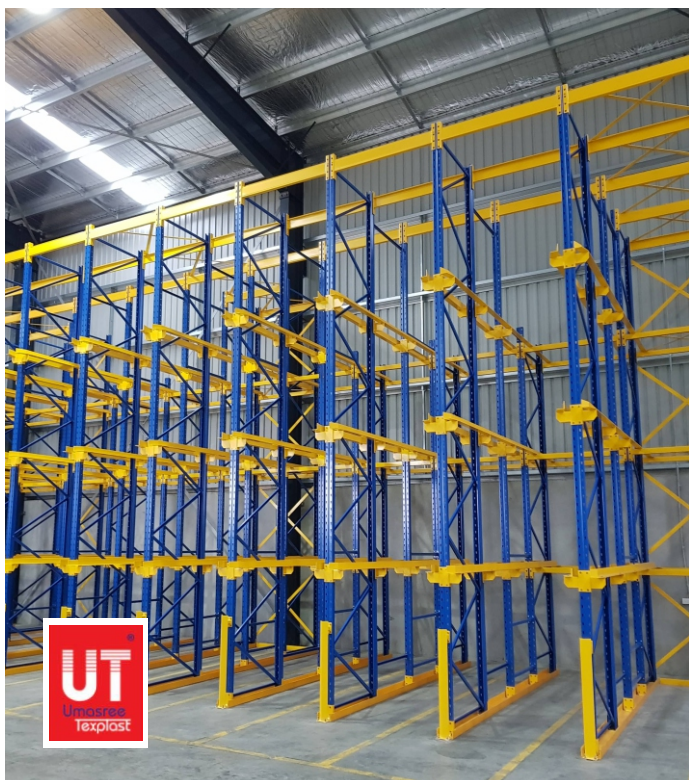



www.storagedi.com | info@darshanindustries.com | 9898025597

MEZZANINE FLOOR



FEATURES

- A strong stable new floor to hold additional storage
- Can be designed to offer the greatest clear space on the ground for additional activities/storage

BENEFITS

- Enables you to maximise the usable height within your warehouse
- Reduces Cost of Construction by allowing efficient use of space
- No extra costs for heat, lights, or air conditioning
- Can be easily enlarged, modified, or moved
- Two tier wide space racks
- Gives additional space without adding ratable value to your property

USERS

- Industries
- Pharma Industries
- Warehousing
- Logistic Companies
- Others





MOULD RACK

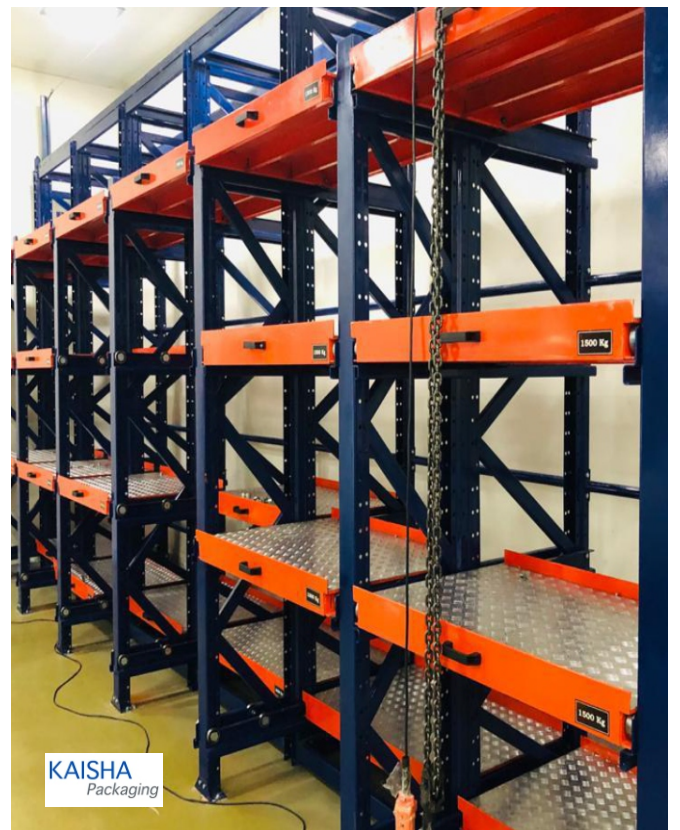



MOTORIZED MOBILE PALLET RACKING



FEATURES

- Suitable For Low-Rise Shelving
- A Finger Force by a Person is Sufficient to Move the Drive Train
- A Floor lock, Secures the Fixed and Mobile Blocks and Prevents Pilferage
- Accidental Movement is prevented through an aisle lock Powder coated

BENEFITS

- Filing cabins
- Light-Weight multiple Product Storage
- Storage of Expensive items

USERS

- Industrie
- Pharma industries
- Library
- Educational institutes
- Offices warehousing
- Logistic companies
- Hospitals
- Other



SHEET STORAGE RACK

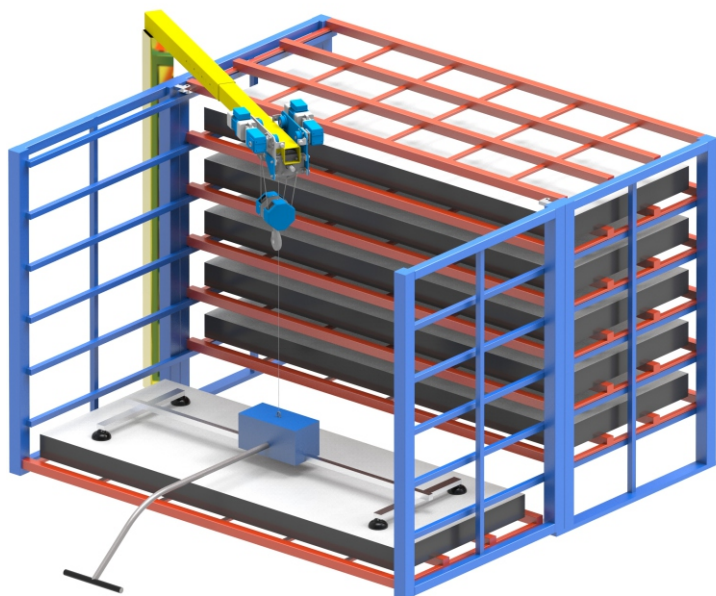
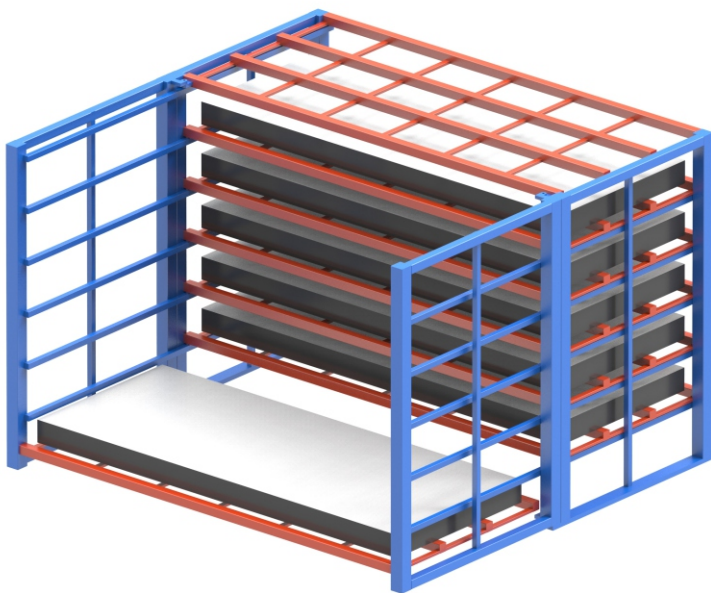
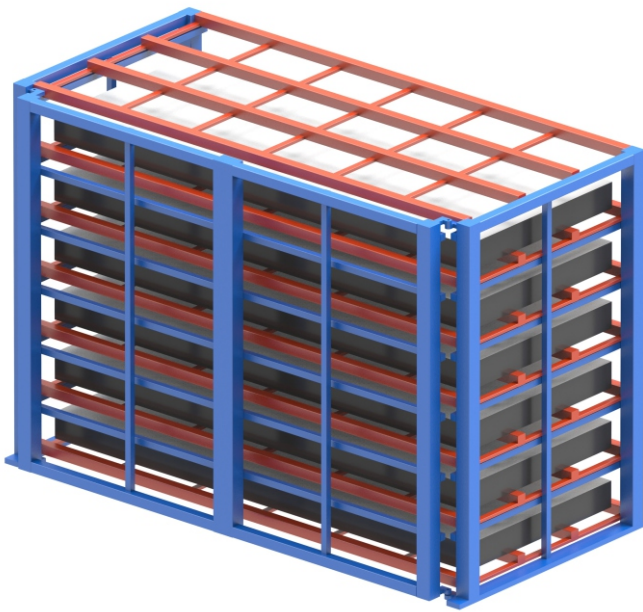

LINEOMATIC®

STANDARD MODEL SPECIFICATION

Locker	Outer Dimension (mm)	Gag	Lock & key	Display	Powder Coated
Storwall	1980 (H) X 450 (D) X 900 (W)	20 22	Y	Y	Y
Glass Door	1980 (H) X 450 (D) X 900 (W)	20 22	Y	Y	Y
06 Door	1980 (H) X 450 (D) X 900 (W)	20 22	Y	Y	Y
08 Door	1980 (H) X 450 (D) X 900 (W)	20 22	Y	Y	Y
09 Door	1980 (H) X 450 (D) X 900 (W)	20 22	Y	Y	Y
12 Door	1980 (H) X 450 (D) X 900 (W)	20 22	Y	Y	Y
18 Door	1980 (H) X 450 (D) X 900 (W)	20 22	Y	Y	Y
24 Door	1980 (H) X 450 (D) X 900 (W)	20 22	Y	Y	Y

CUSTOMIZED SIZES ARE ALSO AVAILABLE



MOBILE RACKING





Document 1

Document 2

Document 3

Document 4

Document 5

TOOLS TROLLEY

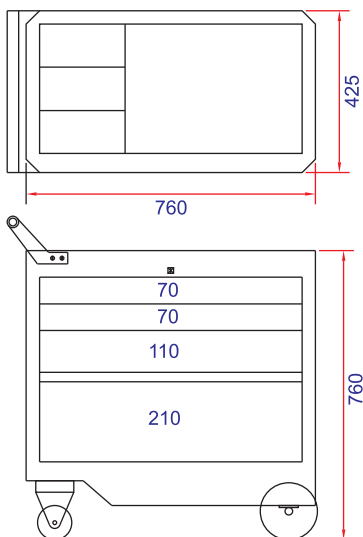

MODEL : 3 DC

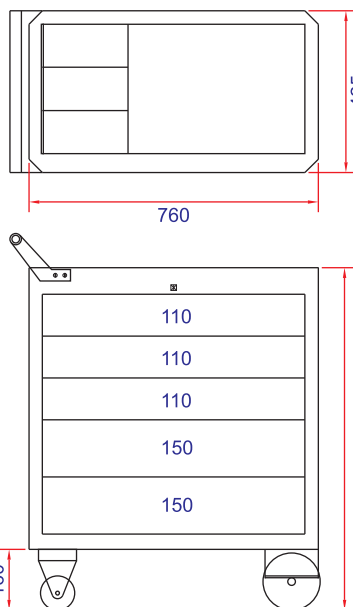
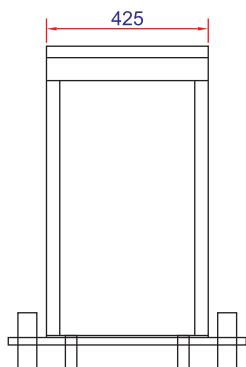

MODEL : 5D

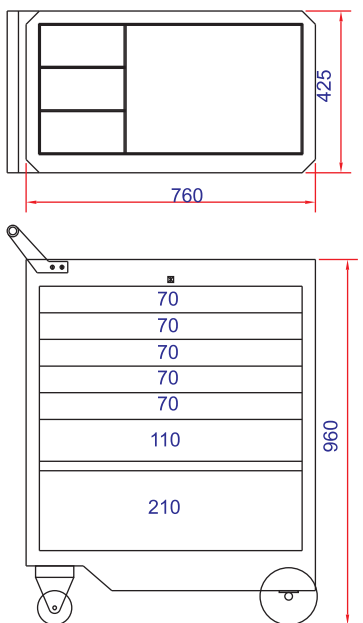
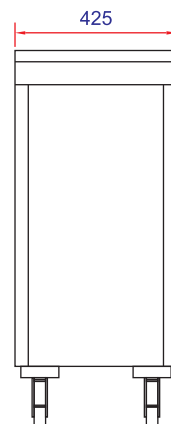

MODEL : 6 DC

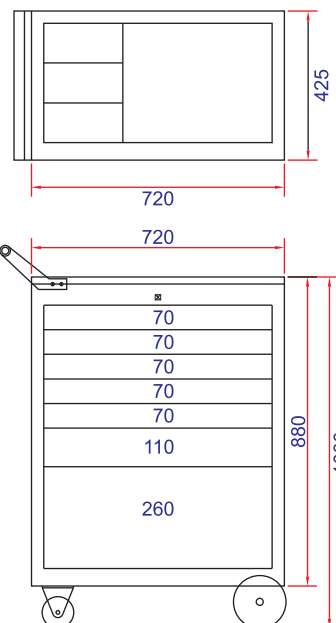
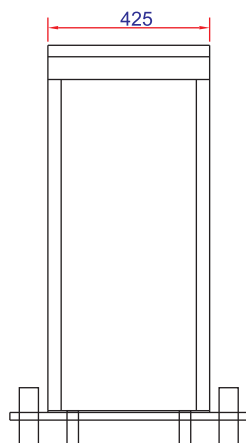

MODEL : SQUARE 7 D

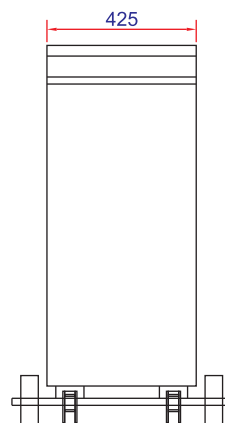



SPIDER

MULTI RANGE OF STORAGE

- AHMEDABAD -

OUR VALUBLE CLIENTS

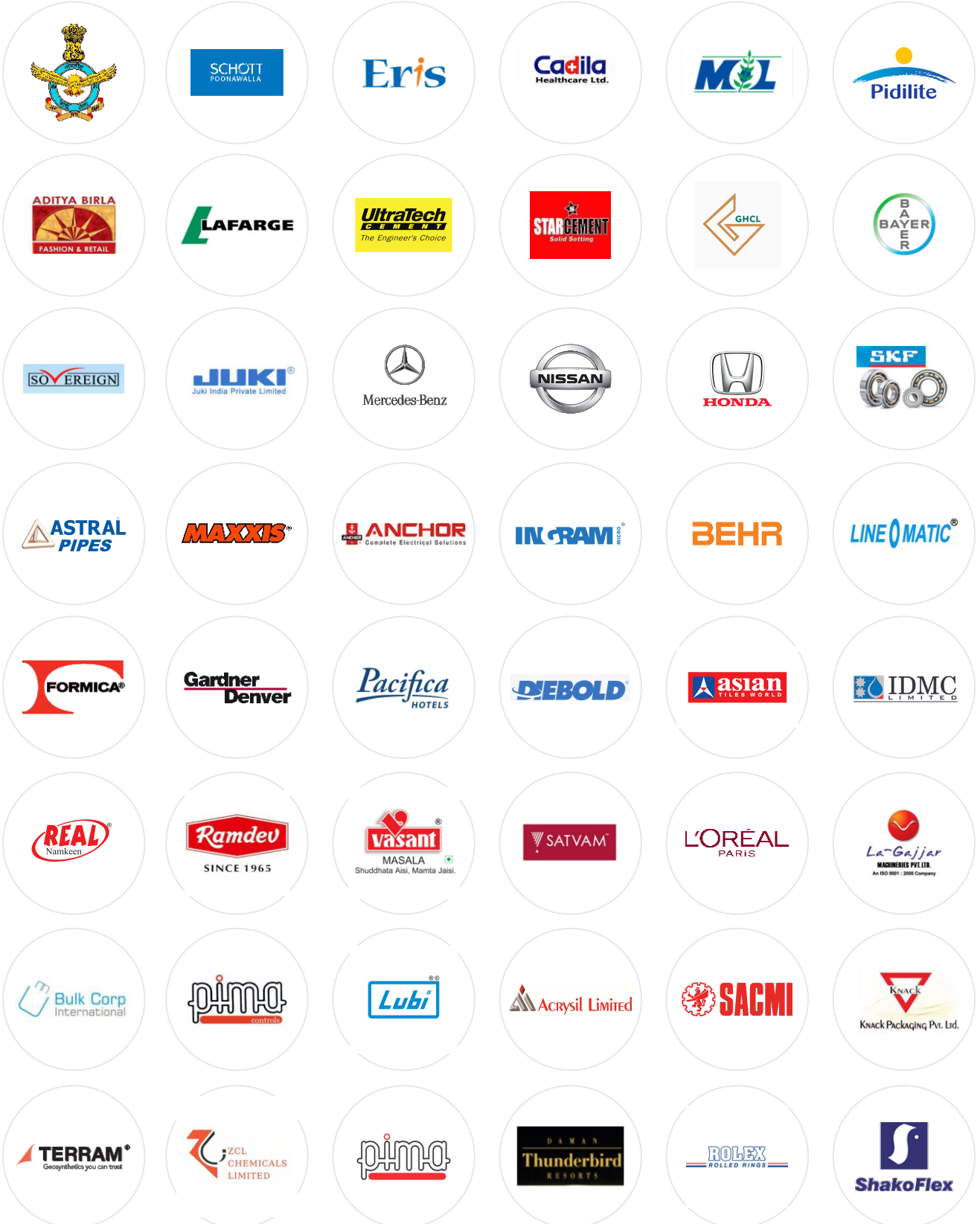





THE INDIA'S LARGEST MANUFACTURER OF PALLET RACKING SHELVING AND LOCKER'S

MOTORIZED MOBILE
PALLET RACKING

SHEET
STORAGE RACK

DRIVIN RACK

MOBILE RACKING

**PALLET
RACKING**

TOOLS TROLLEY

**MEZZANINE
FLOORS**

HEAVY DUTY STORAGE
MOULDED RACK

**LOCKERS
ROLL RACK
TWO-TIER
RACKING**

 **DARSHAN
INDUSTRIES**

AN ISO 9001:2008 COMPANY

PLOT NO.10, SWAPNIL 2 INDUSTRIAL PARK, AHMEDABAD- INDORE HIGHWAY,
NEAR NAYARA PETROL PUMP, KUHA, AHMEDABAD, GUJARAT-382433. INDIA
PHONE: +91 79 2290 2011 - FAX: +91 79 2290 2011 - CELL : +91 98980 25597
E-MAIL: info@darshanindustries.com / sales@darshanindustries.com
WEBSITE: www.darshanindustries.com